

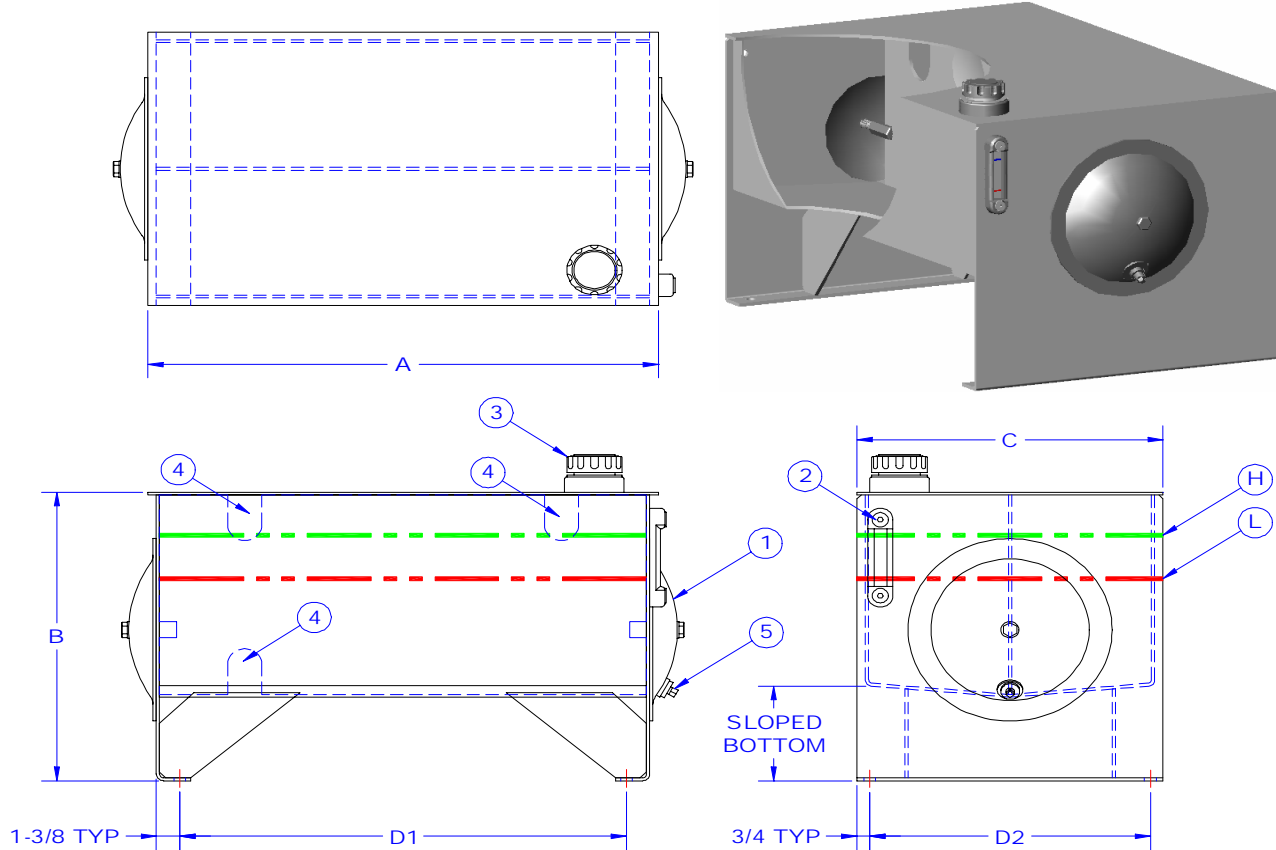

ALL METAL MANUFACTURING

J.I.C. TYPE A RESERVOIR TANK



FEATURES:

- 1. CLEANOUT / INSPECTION COVERS
- 2. SIGHT LEVEL / TEMP. GAUGE
- 3. FILLER BREATHER ON 1" RISER
- 4. HOLES FOR CIRCULATION
- 5. 1/2" NPT DRAIN PLUG
- 6. EXTERIOR COATED WITH HIGH QUALITY POWDER COAT PRIMER.
- 7. INTERIOR CLEANED & COATED WITH RUST INHIBITOR.

RATED CAPACITY (GAL)	ALL METAL PART NUMBER	TANK DIMENSIONS			MOUNTING CENTERS		ACTUAL CAPACITY			MATERIAL THICKNESS		SHIPPING WEIGHT (lbs)
		A LENGTH	B HEIGHT	C WIDTH	D1 ±1/8	D2 ±1/8	END COVER	HIGH (H) (GAL)	LOW (L) (GAL)	END	TOP	
20	AM00020JIC	30	19	18	26 1/4	16 1/2	12	23.00	16.82	7 GA.	7 GA.	125
30	AM00030JIC	36	19 3/8	24	32 1/4	22 1/2	12	34.50	24.33	7 GA.	7 GA.	175
40	AM00040JIC	36	21	24	32 1/4	22 1/2	12	46.00	35.83	7 GA.	7 GA.	190
50	AM00050JIC	36	23	24	32 1/4	22 1/2	16	57.50	47.33	7 GA.	7 GA.	200
60	AM00060JIC	48	20 11/16	27	44 1/4	25 1/2	16	69.00	53.48	7 GA.	3/8"	310
80	AM00080JIC	60	21 1/2	27	56 1/4	25 1/2	16	92.00	72.49	7 GA.	3/8"	395
100	AM00100JIC	60	23 1/2	27	56 1/4	25 1/2	16	115.00	95.49	7 GA.	3/8"	415
120	AM00120JIC	60	27	30	56 1/4	28 1/2	16	138.00	116.21	3/8"	3/8"	610

NOTES:

LENGTH MEASUREMENTS IN INCHES
 10 - 50 GALLON TANK TOPS ARE 3/16" THICK
 60 - 300 GALLON TANK TOPS ARE 3/8" THICK
 400+ GALLON TANK TOPS ARE 1/2" THICK
 10 - 100 GALLON TANK ENDS ARE 3/16" THICK
 120+ GALLON TANK ENDS ARE 3/8" THICK

1. CLEANOUT / INSPECTION COVERS
2. SIGHT LEVEL / TEMP. GAUGE
3. FILLER BREATHER ON 1" RISER
4. HOLES FOR CIRCULATION

RATED CAPACITY GALLONS	5. 1/2" NPT DRAIN PLUG 6. EXTERIOR COATED WITH HIGH QUALITY POWDER COAT PRIMER. 7. INTERIOR CLEANED & COATED WITH RUST INHIBITOR.				ALCULATED HEIGHT	VOLUME AT 15%
20					13.3	23
30					12.3	34.5
40					15.7	46
50					19.1	57.5
60	46.625	15.5	25.625		15.5	69
80	58.625	16.3	25.625		16.3	92
100	58.625	19.8	25.625		19.8	115
120	58.625	21.1	28.625		21.1	138